



# ***High Definition Digital Video and Digital Audio***

***for  
Chrome 400 Series  
Graphics Processors***

***A  
S3 Graphics  
White Paper***

# CHROME

## Introduction

The current trend towards using the personal computer (PC) as an entertainment system capable of displaying High Definition (HD) video, gaming, and graphics content has allowed the PC to become the centerpiece of home media entertainment systems. In its Chrome 400 Series graphics processors, S3 Graphics provides media-centric PC technologies which focus on the “digital living” room and merge PC and consumer electronic (CE) multimedia functionalities. Major content providers such as Hollywood movie studios and game publishers are creating HD media which allows the user to take their entertainment system viewing to the next level when using S3 Graphics’ solutions for PC-CE connectivity.

HDMI (High-Definition Multimedia Interface) carries high-speed, uncompressed video and audio data streams across a single cable to simplify device-to-device connections, and provide additional benefits of HDMI, as described in more detail below. To bridge the PC-CE gap for cross-platform adoption has allowed HDMI, the CE interface of choice, to make inroads into the PC space, as hardware vendors like S3 Graphics incorporate the technology into their advanced devices.

## HDMI Background

The HDMI specification was developed variety of reasons.

- Existing HDTV connections, such as component video (YPbPr), were sufficient for today’s standard HDTV sets, but lacked the capability to support higher frame rates, resolutions higher than 1080p, and greater color depth per pixel, as High Definition quality increases with the introduction of each new generation of consumer entertainment devices.
- HDMI digital signals carry more information at higher speeds than analog signals or other digital formats. Thus, more options exist as new features are introduced.

- The conversion of data from digital to analog back to digital is a lossy process which degrades the quality of the resulting image. As digital TV sets become the norm, it is better to keep data in digital format from the beginning in order to minimize the possibility of introducing errors in the data stream.
- Existing connection options required separate cables for audio and video, so clutter was inevitable. The HDMI connector design aims to replace both audio and video cables with a single, high-bandwidth, user-friendly cable (figure 1).

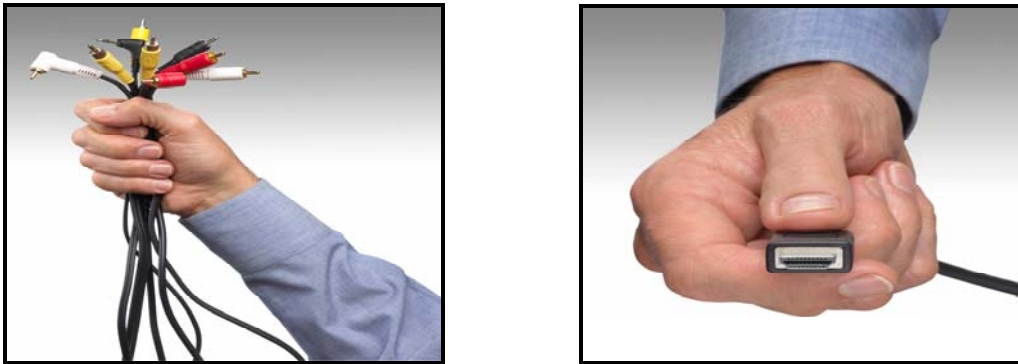

**Figure 1: Separate A/V cables (left), HDMI cable with A/V**  
 (Source: HDMI.org website)

- The move to HD content utilizing Blu-ray and HD-DVD discs has movie studios excited, but the studios are cautious at the same time because, without a solid content protection mechanism, there is a potential for copyright infringement and unauthorized distribution of protected content. With analog standards, content protection did not guarantee misuse of intellectual property. The HDMI standard has a higher level of protection to ensure content is secured from source to destination, using the HDCP (High-bandwidth Digital Content Protection) protocol. Because of the copy protection ensured by HDMI, movie studios fully support this technology as their CE connection of choice.

HDMI is an industry supported high-speed uncompressed digital interface based on TMDS (Transition-Minimized Differential Signaling). TMDS was also used by DVI, a predecessor of HDMI, and HDMI is backward compatible with DVI. The main difference between the standards is that DVI carries only video data while HDMI carries both audio and video data, and does so at a much higher data rate. There is also a size difference between the two connectors (figure 2), making HDMI more attractive in multiple form-factor designs.



**Figure 2: HDMI connector (left) compared to DVI connector (right)**

The example in figure 3 shows a PC displaying a movie on an external device through the HDMI interface. The system uses HDCP to provide a secure connection from the HD-DVD or Blu-ray disc player to the GPU, across the PCI Express bus, and then out to the HDMI display device.

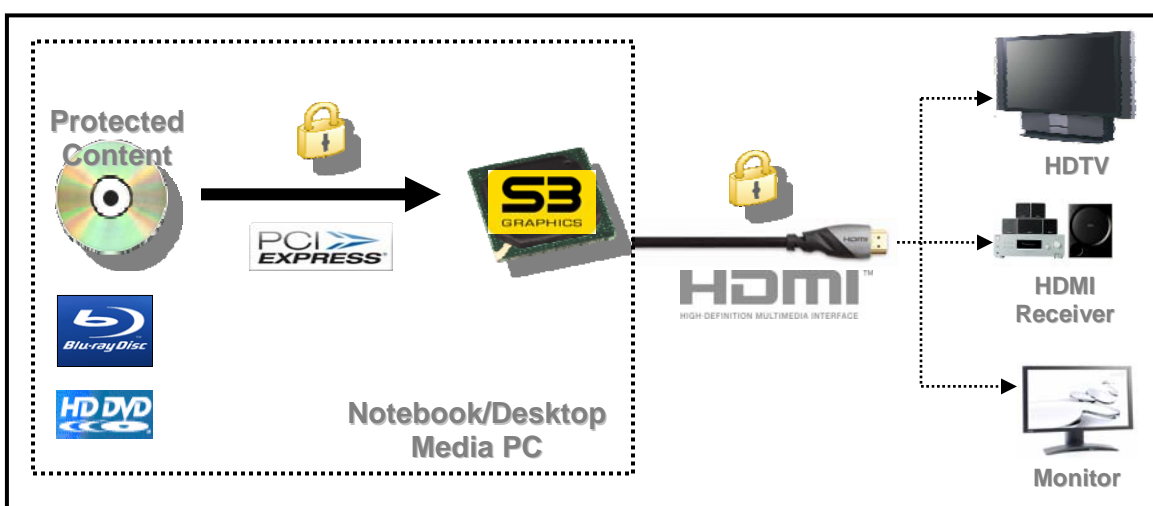

**Figure 3: Notebook/Desktop (PC) HDMI Connection Example**

There are currently three types of HDMI connectors: Type A, Type B, and Type C. Type A and C are used for single-link TMDS connections and Type B is used for dual-link TMDS support for high resolution displays. The Type B connector size is slightly larger than the Type A size because of the dual-link configuration. The Type C (single-link) connector is a compact design, targeted for mobile and small form factor applications.

## HDMI Specification Revision History

Since its introduction at the end of 2002, the HDMI specification has gone through a few revisions to support the evolution of higher resolution displays in the market. S3 Graphics Chrome 400 Series processors were designed for compatibility with the HDMI specification revision 1.2. Subsequently, the HDMI 1.3 specification has been released. It is a forward-looking standard in its capability to support future extensions to the specification.

HDMI 1.0 (2002)	HDMI 1.1 (2004)	HDMI 1.2 (2005)
Backward compatible with DVI standard	Backward compatible with HDMI 1.0 and DVI	Backward compatible with HDMI 1.0/1.1 and DVI
Initial Specification	Added support for DVD audio (DVDA)	Added support for Super Audio CD (SACD)
		Added Consumer Electronic Control (CEC) features
		Added PC support for native RGB color space

**Table 1: HDMI Version Comparison**

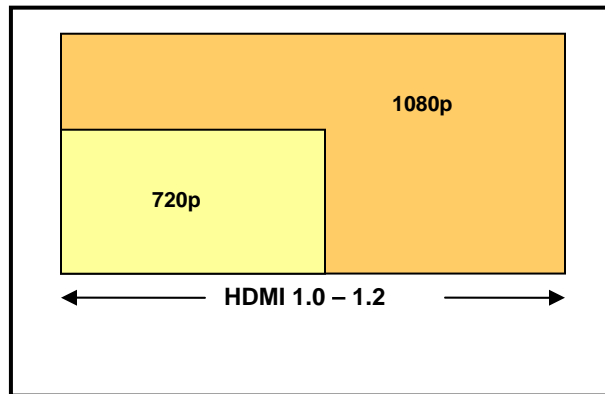

**Figure 4: Display resolution support**

## HDMI Topology

Figure 5 shows the basic topology of a single-link HDMI interface. There are three unidirectional differential pair data signals and one differential pair clock signal to carry audio, video, and auxiliary data. The Display Data Channel (DDC) is a bi-directional signal used for device communication, configuration, and status exchange between the source (transmitter) and sink (receiver) device. The source will read the information located on the sink's EDID ROM to obtain this information. The Consumer Electronic Control (CEC) bi-directional channel is an optional feature that enables the user to control multiple HDMI devices connected together using a single remote control.

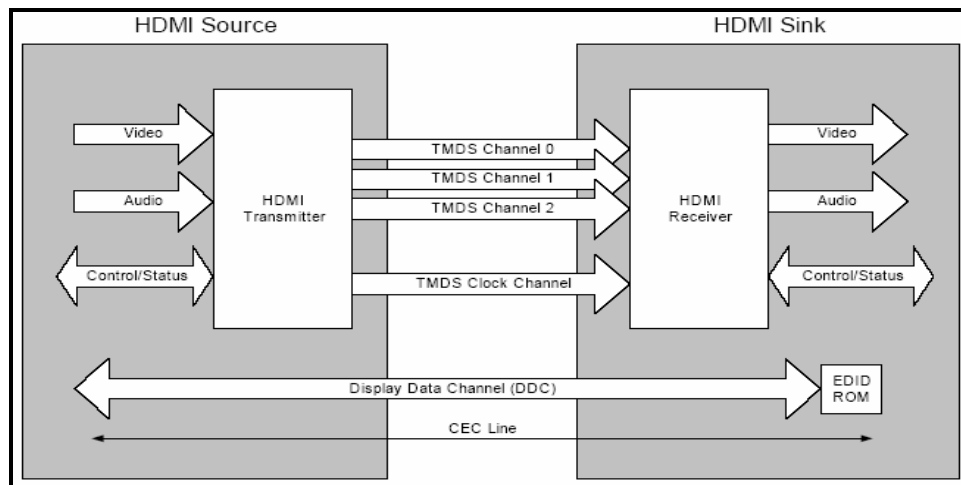

**Figure 5: HDMI Link Block Diagram**  
(Source: HDMI 1.2 Specification)

The clock channel typically runs proportional to the video pixel rate and is used by the receiver to recover the data on the three data channels. The pixel rate and clock channel scale up as the resolution increases, from 25MHz to 165MHz. When lower resolutions (with native pixel rates below the 25MHz minimum frequency such as NTSC (13.5MHz)) are viewed, the TMDS link will use a pixel repetition technique to effectively double the pixel clock to be within the clock rate specification.

The HDMI link uses three operating modes to transmit data, audio, and control (CEC/DDC) data: Video Data period, Data Island period, and Control period. The Video Data period is the period during which the active pixels for an active display line are sent to be displayed at the receiver. The Data Island period is analogous to the horizontal/vertical blanking period in analog displays, i.e., the period during which auxiliary data can be sent. In HDMI auxiliary and audio data packets are sent during the Data Island period. A Control period is required between any two periods that are not Control Periods.

At the transmitter, video data is converted from 8-bits to 10-bits (DC-balanced) and sent across each channel at a rate of 10-bits per clock period. The pixel format is in RGB 4:4:4, YCbCr 4:4:4, or YCbCr 4:2:2 and will be encoded by the transmitter based on the source data format and receiver support capabilities. Devices are required to support 24-bits per pixel.

Audio is transmitted at the video clock pixel rate since video dominates the bandwidth of the HDMI interconnect. Since the video clock rate is different from the audio rate, the audio data goes through a process called Audio Clock Regeneration (ACR) at the receiver to recreate the correct audio sample clock at the receiver.

Auxiliary data is sent across the TMDS channels in an InfoFrame packet format. Auxiliary Video Information (AVI) InfoFrames tell the receiver the capabilities of the transmitter (for example, pixel encoding or enhancement support). Audio InfoFrames describe details about the audio data format and rate so the receiver can synchronize itself with the incoming audio data.

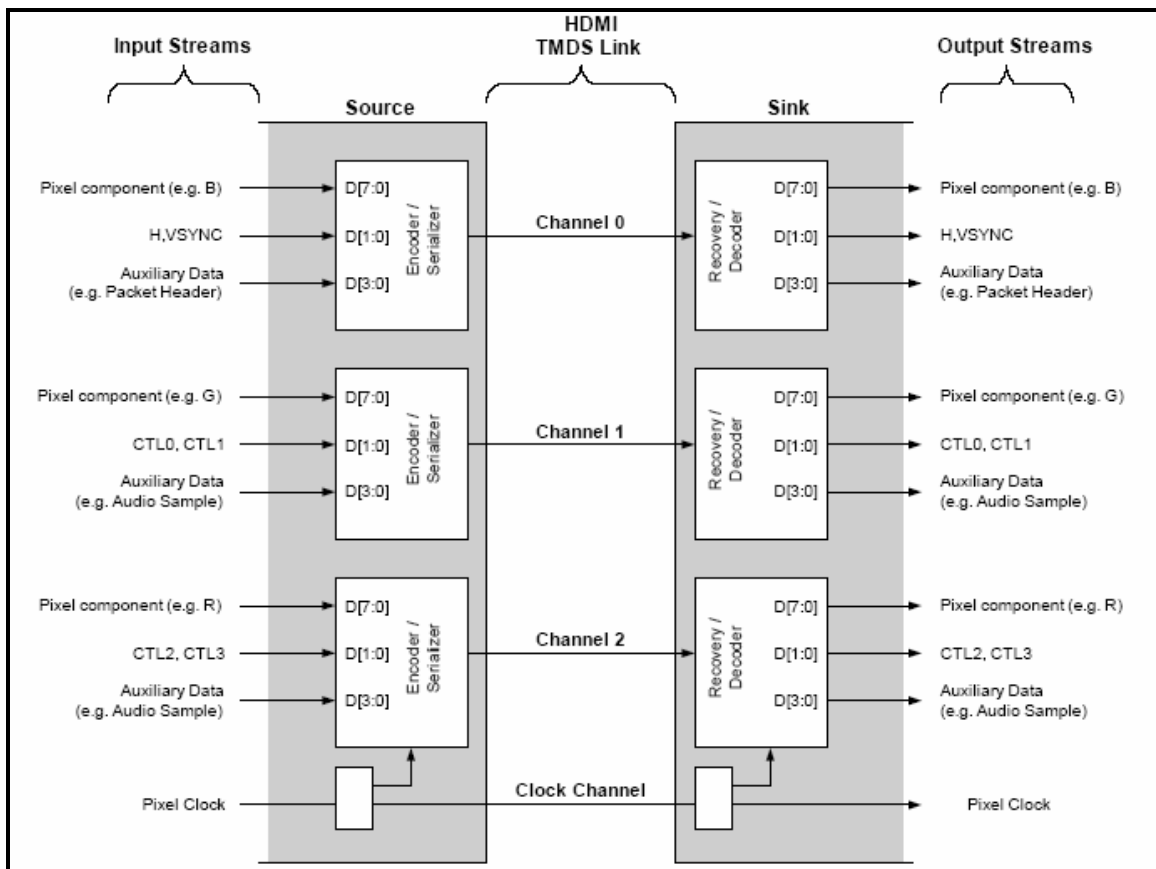

**Figure 6: HDMI Link Architecture**  
(Source: HDMI 1.2 Specification)

## Audio/Video Encoding

Previous generations of graphics processors only needed to process video (display) data. With the growth in popularity of HDMI, GPU designers are developing methods for incorporating HDMI audio as well as visual data within the same data stream, to provide compliance with HDMI specifications. At first glance the idea of providing an audio source to the display seems non-trivial. The main problems with this type of architecture are that the structures of audio and video data are completely different and they are located at different software stacks in main memory. In addition, the processing of audio data requires a fixed function unit (audio CODEC) to convert the audio data to a usable form, and any timing skew can create lip sync problems, similar to those that appear in poorly dubbed movies.

Two methods can be used to facilitate the embedding of audio along with the video stream. The first method utilizes an external chip (HDMI transmitter) that will sync and embed the audio data provided to it by the system audio output and the video data provided by the GPU. Once the data is multiplexed together, the transmitter can output the HDMI signal. This technique is sufficient for basic HDMI use; however, as the data rate increases, the synchronization between audio and video could become a problem, since audio typically takes less time to process than video. Because audio is transmitted during the video blanking (Data Island) interval, it has a small sampling window during which it can be manipulated to prevent timing mismatches with the video.

The best quality HDMI audio/video synchronization is available only when the audio and video data originate from the same source. With the second method HDMI transmitter functionality is moved into the same chip that is used to process both audio and video. S3 Graphics has taken this more efficient route in the Chrome 400 Series GPUs by designing a Unified Audio Architecture (UAA) with an embedded HD audio controller. Both the hardware and the software support are fully compliant with audio industry standards as well as with the conventions for PCI Configuration space and Microsoft compatibility guidelines for Windows® operating systems, including Windows Vista®. Utilizing the S3 Graphics advanced ChromotionHD 2.0 video processing engine, Chrome 400 Series processors match video and audio signals to output full resolution premium HD content for the best visual and audio quality.

## **HDCP (Content Protection)**

HDCP encrypts HD digital content as it is transmitted from a digital video source to a sink capable of decrypting the HDCP-protected content for viewing. The connection (for example, watching HD movies on an HDTV connected to a PC) is authenticated with a unique session key that creates a secure point-to-point connection. This connection is constantly monitored to ensure the connection is not compromised or bypassed for unauthorized users to view or copy. If the connection is deemed insecure, HDCP will revoke the session key and users will not be able to play content at the full HD level. Each device has 40 unique 56-bit secret keys (Device Private Keys) and an identifier (KSV) that is 40-bits long. During authentication the transmitter will request the KSV of the receiver and determine if it is valid. If the KSVs are valid then the transmitter and receiver each create a 56-bit shared secret value using the other device's KSV. Based on the decoding of the shared secret value, each device can determine if the connection is legal. If a connection is deemed illegal, a user can still view media content, but at a lower quality level. If the connection is between two HDCP devices, then the high quality of full HD output can be experienced. The S3 Graphics Chrome 400 Series has an internal keystore and logic to encrypt the HDCP keys and decrypt the HDCP encryption on the fly.

The secure connection HDMI offers have given HD content providers, such as movie studios and game developers, the confidence to create enhanced multimedia content for both consumer and PC markets. In the past, content providers had copyright protection issues, especially from PC based devices, so little HD media was made available for the PC user. As the PC becomes more entertainment centric and capable of providing reliable content protection, content providers will see the PC as another CE device. Thus, they will be in a position to create new and exciting media not only to extend their market reach but also provide the PC consumer with more HD content options.

## **Conclusion**

HDMI is a forward looking and expanding technology capable of supporting market shifts and evolving adaptive standards. As the PC transitions towards becoming part of the digital entertainment environment, HDMI support becomes an essential component of this paradigm shift.

S3 Graphics Chrome 400 Series processors provide support for HDMI audio and video and can be designed into PCs as well as other CE devices. With their Unified HD Audio Architecture coupled with the ChromotionHD 2.0 video engine and integrated HDCP support, Chrome 400 Series processors are able to efficiently process audio and video, providing a seamless High-definition Multimedia Interface -- the way it was envisioned to be.